



TEM Thermal Deburring



T250

Rapid and cost-effective deburring

The T250 thermal deburring machines provide a fast and reliable solution for removing all internal and external burrs simultaneously in a single operation. They are designed to accommodate medium- to large- production volumes, as well as handle a variety of difficult to deburr workpieces.

Available in multiple chamber sizes with maximum operating pressure of 23 bar and cycle time from 30 to 60 seconds.



FEATURES and BENEFITS

- + **100 % deburring - cleanliness**
Consistent, repeatable deburring of internal hard to reach intersected / cross-sectional holes and external contours of components.
- + **Precise Gas metering via mass flow control**
Mass flow control devices are used to accurately regulate the gas mixture to deliver the right pressure in the chamber.
- + **Hydraulically secured closure plates**
The deburring chamber is hermetically sealed off, eliminating contamination concerns and guaranteeing production safety.
- + **User-friendly and expandable Programmable Logic Controller (PLC) / HMI**
Software facilitates quick parameter set-up; convenient machine monitoring with integral fault diagnostics.
- + **Integrated noise suppression enclosure**
The enclosure prevents noise emissions into the production environment and ensures safety for the machine operator.
- + **Productivity**
Significant improvement in the productivity of the overall process of TEM in combination with post-washing.



EXTRUDE
HONE®

TECHNICAL INFORMATION

T250

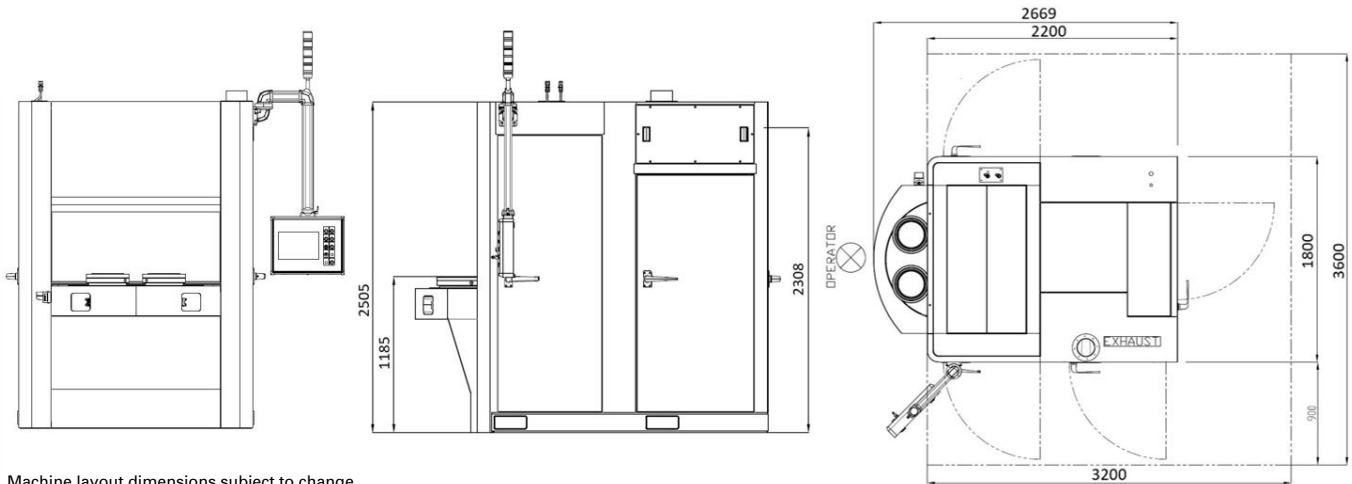

Machine layout dimensions subject to change.

ELECTRICAL SPECIFICATIONS

- Main control cabinet integrated into the noise reduction enclosure.
- 12" touchscreen HMI
- Manual or automatic mode of operation

Power

Voltage 400 VAC; 3 P/N/PE/50 Hz
*Other voltages available on request

Controls

PLC Siemens S7-1500 (Fail Safe PLC)*
*Other controls are available as option.

HMI Siemens Comfort Panel 12" touch screen**

** Optional process HMI display and interface to master computer are available.

CONNECTION REQUIREMENTS

	Water	Pneumatics	Oxygene	Methane
Port	G 1/2"	G 1/2"	G 1/2"	G 1/2"
Pressure	min 3 bar	min 5 bar	min 25 bar	min 25 bar

MACHINE SPECIFICATIONS

- Two-post-portal machine frame construction.
- Clamping forces up to 1.8 MN
- Indexing table equipped with up to five closure plates.

Noise Level < 70 dB(A)
Weight T250: approx. 10.000 kg

Cycle Time (single ignition) 30 - 60 seconds

NOTE: Specifications and availability are subject to change without notice.

MACHINE CONFIGURATION

	Chamber size (ØxH)	Chamber Pressure (bar)
T250	250 x 150 / 300	14
	200 x 150 / 300	19
	150 x 150	20
	120 x 150	24

VALUES FOR GAS MIXTURE PRESSURE

Material	Natural Gas
Steel	8-20 bar
Cast Iron	5-20 bar
Zinc	5-10 bar
Aluminium	5-10 bar
Brass	8-20 bar

Fuel can be natural gas / methane.

SAFETY

- Exhaust fan with vacuum sensor
- Gas detection system
- Mixing valve tester
- Probing station with integrated seal cleaner

ACCESSORIES/OPTIONS

- Multiple chamber options – diameter and height
- Gas compressor
- Closed loop cooling system
- Full automation



All machines in this series comply with the applicable EU Directives governing machine safety and bear the CE mark. They also comply with accident prevention and the VDE and VDI regulations, as well as the requirements concerning electromagnetic compatibility.