



TEM Thermal Deburring



T450

Rapid and cost-effective deburring

The T450 thermal deburring machine provides a fast and reliable solution for removing all internal and external burrs simultaneously in a single operation. They are designed to accommodate medium- to large- production volumes, as well as handle a variety of difficult to deburr workpieces.

Available in multiple chamber sizes with maximum operating pressure of 20bar and shortest cycle time of 55 seconds.



FEATURES and BENEFITS

- + **100 % deburring - cleanliness**
Consistent, repeatable deburring of internal hard to reach intersected / cross-sectional holes and external contours of components.
- + **Precise Gas metering via mass flow control**
Mass flow control devices are used to accurately regulate the gas mixture to deliver the right pressure in the chamber.
- + **Hydraulically secured closure plates**
The deburring chamber is hermetically sealed off, eliminating contamination concerns and guaranteeing production safety.
- + **User-friendly and expandable Programmable Logic Controller (PLC) / HMI**
Software facilitates quick parameter set-up; convenient machine monitoring with integral fault diagnostics.
- + **Integrated noise suppression enclosure**
The enclosure prevents noise emissions into the production environment and ensures safety for the machine operator.
- + **Productivity**
Significant improvement in the productivity of the overall process of TEM in combination with post-washing.



TECHNICAL INFORMATION

TEM T450

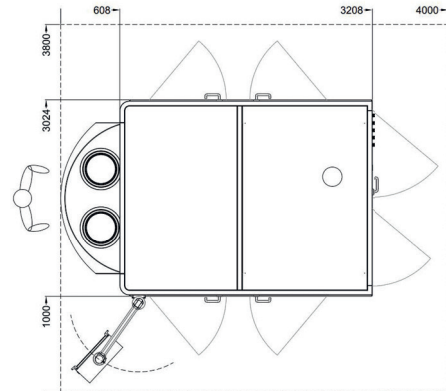
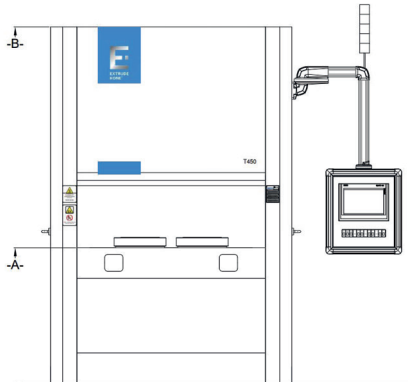

ELECTRICAL SPECIFICATIONS

- Main control cabinet integrated into the noise reduction enclosure.
- 15" touchscreen HMI mounted on a swing arm
- Manual or automatic mode of operation

Power

Voltage 400 VAC; 3 P/N/PE/50 Hz
*Other voltages available on request

Controls

PLC Siemens S7-1500 (Fail Safe PLC)*
*Other controls are available as option.

HMI Siemens Comfort Panel 15" touch screen**

** Optional process HMI display and interface to master computer are available.

CONNECTION REQUIREMENTS

	Water	Pneumatics	Oxygen	Methane
Port	G 1/2"	G 1/2"	G 1/2"	G 1/2"
Pressure	min 3 bar	min 5 bar	min 20 bar	min 20 bar

MACHINE SPECIFICATIONS

- Three-post-portal machine frame construction.
- Clamping forces up to 4.5 MN.
- Indexing table equipped with up to five closure plates.

Noise level < 70 dB(A)
Weight approx. 12.000 kg
Dimensions W x D 2600mm x 3208mm
Dimension A and B depending on chamber height.
Chamber Height 400mm A: 1120mm and B 2950mm
Chamber Height 500mm A: 1120mm and B 2950mm
Chamber Height 600mm A: 1439mm and B 3100mm

Cycle Time (single ignition) 55-75 seconds

MACHINE CONFIGURATIONS

	Chamber size (ØxH)*	Chamber Pressure (bar)
T450	320x400	20
	400x400	14
	400x500	14
	400x600	14

More chamber sizes available on request

VALUES FOR GAS MIXTURE PRESSURE

Material	Natural Gas
Steel	8–20 bar
Cast Iron	5–20 bar
Zinc	5–10 bar
Aluminum	5–10 bar
Brass	8–20 bar

Fuel can be natural gas / methane.

SAFETY

- Exhaust fan with vacuum sensor
- Gas detection system
- Mixing valve tester
- Probing station with integrated seal cleaner

ACCESSORIES/OPTIONS

- Multiple chamber options – diameter and height
- Gas compressor
- Closed loop cooling system
- Full automation
- Hydrogen version



NOTE: Specifications and availability are subject to change without notice.

All machines in this series comply with the applicable EU Directives governing machine safety and bear the CE mark. They also comply with accident prevention and the VDE and VDI regulations, as well as the requirements concerning electromagnetic compatibility.